

# ACCURATE LOCK AND HARDWARE CO. LLC.

Manufactures of  
CUSTOM LOCKS AND ARCHITECTURAL HARDWARE

## HARMON HINGE INSTALLATION TEMPLATE 2-1/4 THK. DOOR

ANNIE PLACE, STAMFORD, CT. 06902  
(203) 348-8865 FAX (203) 348-5234  
E-MAIL: [Accurateh@aol.com](mailto:Accurateh@aol.com)  
[www.Accurate.to](http://www.Accurate.to)

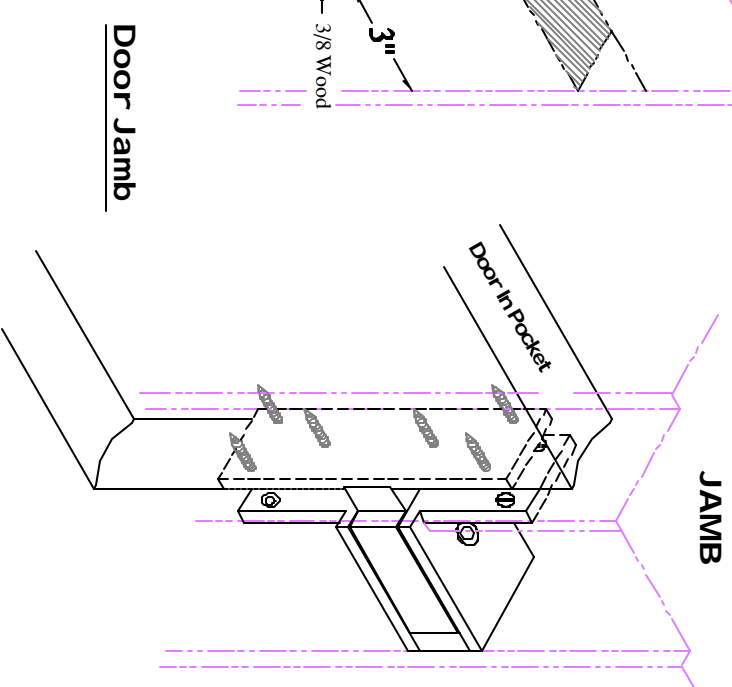
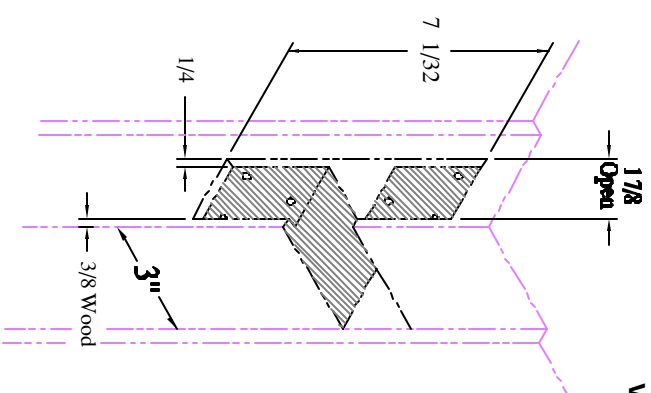
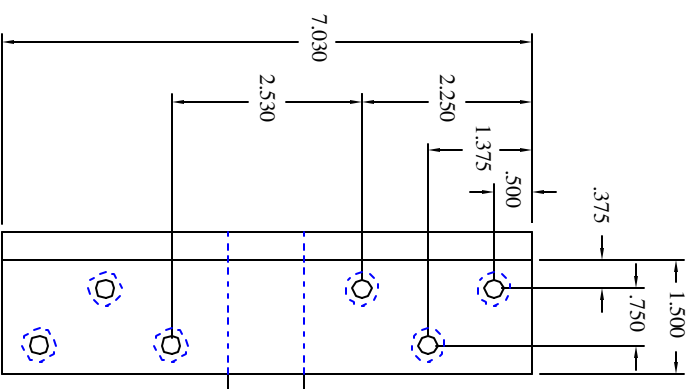
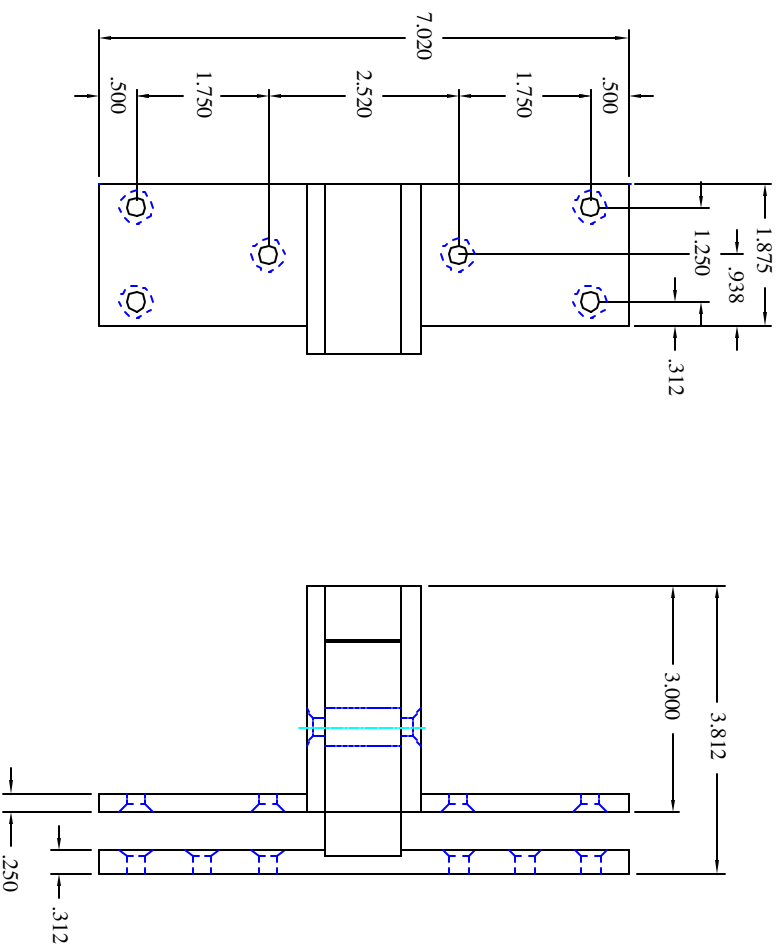
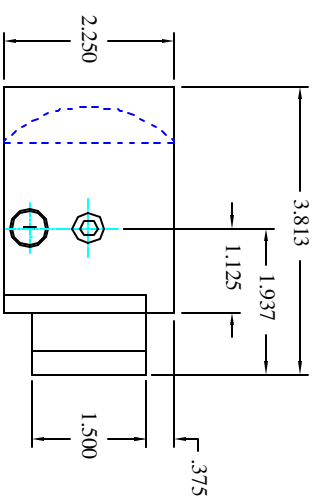

Dimensions	
Door Size	2.25"
$\text{A}^{\circ}$	2.25"
$\text{B}^{\circ}$	1.125"
$\text{R}^{\circ}$	1.656"

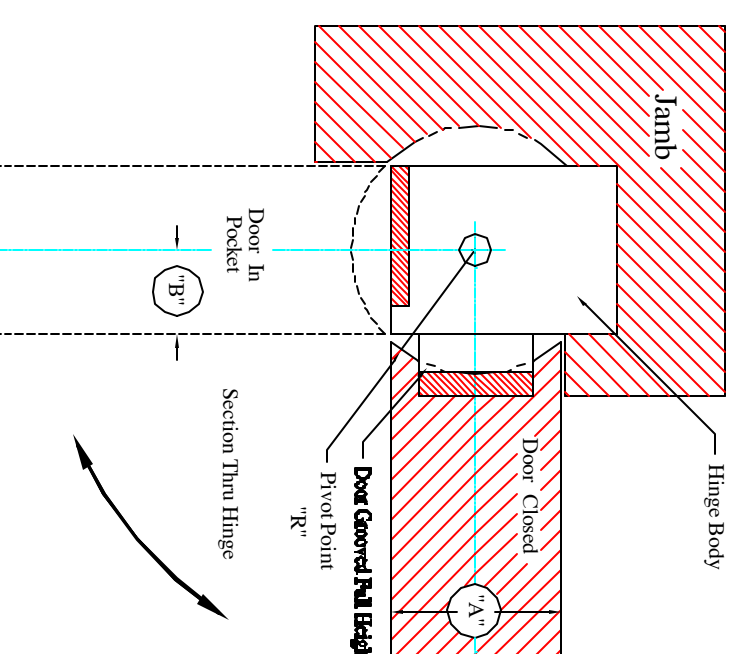

ACCURATE Template Harmon Hinge is made to conform to this drawing  
Machine Screw Size - 3/4 x 12-24 F.H  
Wood Screw Size - 1-1/4 x 12 F.H